



AIR CONDITIONING



REFRIGERATION



HEATING



EN

hot water economy

CONDENSATE REMOVAL PUMP

Built of heat resistant cyclopy, this economy pump is designed to handle high water temperatures.

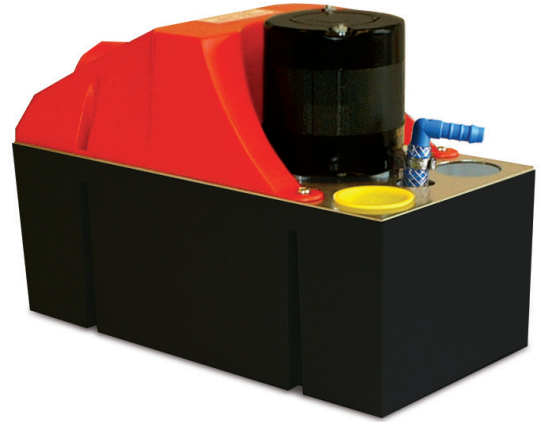

900L/h max. flow



6m max. rec. head
(flow rate 350L/h)

KEY FEATURES

- High performance
- Handles 80°C water
- 2 inlets

SUITABILITY

- Up to 1200kW / 4m Btu/h
- Humidifiers; Boilers; Refrigeration; Air handling units (AHUs)

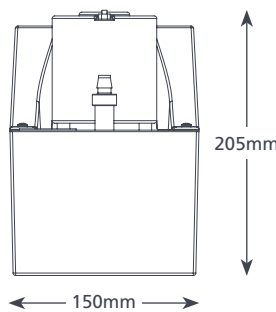
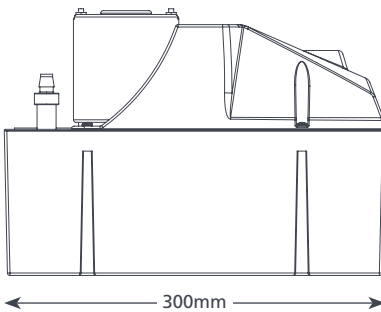

3.6 kg

HOT WATER ECONOMY SPECIFICATIONS

Max. flow	900L/h @ 0 head
Max. rec. head	6m
Tank capacity	4L
Sound level@1m	60dB(A)
Power supply	230V AC 50-60Hz 1.5A
Rated	Non continuous
Class	I appliance
Max. unit output	1200kW / 4m Btu/h
Max. water temp	80°C / 176°F
Inlet/outlet size	x2 40mm in, 10mm out
IP Protection	IPX1
Safety switch	4.0A Normally closed
Thermal protection	✓
Fully potted	n/a
Self priming	n/a

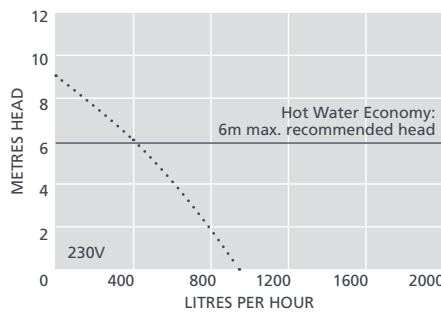

SUGGESTED XTRA ACCESSORIES

Description	Part No.
Tank pump connector 16mm-21mm	FP2011
Tube To Soil Stack Adaptor	FP2038
Vinyl Tube Braided 3/8" (10mm)	AX5111
StayClean Tablets	FP2418

Xtra For more installation accessories take a look at our Aspen Xtra range

HOT WATER ECONOMY OPTIONS

Hot Water Economy	FP2092/2
-------------------	----------

IN THE BOX

- Hot Water Economy Pump • 2m power cable
- Install manual

Download manual at aspenpumps.com

Information correct at time of going to press.



aspenpumps.com

+44 (0)1323 848842

sales@aspenpumps.com

Making life easier for the installer