

COMPRESSOR

Displacement (cm ³)	5.67
Diameter (mm)	21.99
Stroke (mm)	14.9
Net Weight (Kg)	10.1
Oil type	ISO VG 46 ESTER
Oil charge (cm ³)	300

MOTOR

Approximate Power (CV)	1/4
Voltage/Frequency (V/Hz)	220V 50Hz
Voltage range (V)	187-264
Code	61.569
Type	CSIR
Phase number	1 PH
Locked rotor current (A)	10.6
Main W. resist. at 25°C (Ω)	8.26
Start W. resist. at 25°C (Ω)	34.77

APPLICATION

Application	High/Mid. back pressure
Refrigerant	R404A
Evaporating (°C)	-25 to 10
Expansion	Capillar/Valve
Comp. cooling	Fan cooled
Max. ambient temp. (°C)	43

NOMINAL PERFORMANCE	CYCLE C	CYCLE D
Cooling capacity (kcal/h)	556	700
Input power (W)	424	440
EER (kcal/Wh)	1.31	1.59
COP (W/W)	1.52	1.85
Current (A)	2.37	2.44

TEST CONDITIONS

Evaporating temp. (°C)	5.0	7.2
Condensing temp. (°C)	55.0	55.0
Liq.t. entering expan. (°C)	55.0	46.0
Ambient t. and return (°C)	32.0	35.0
Tens/Freq (V/Hz)	220V 50Hz	220V 50Hz

ELECTRICAL COMPONENTS

Relay	2014 131.	
Pick-Up (A)	5,30	
Drop-Out (A)	4,50	
Protector	MRT38AMK	T0168
Current (A)	10.0	9.5
Time check (seg)	7.5-14	7.5-14
Disc temp. (Open/Close) (°C)	105.0 / 61.0	105.0 / 61.0
Starting capacitor (μF/V)/F/V)	47- 56 / 330	

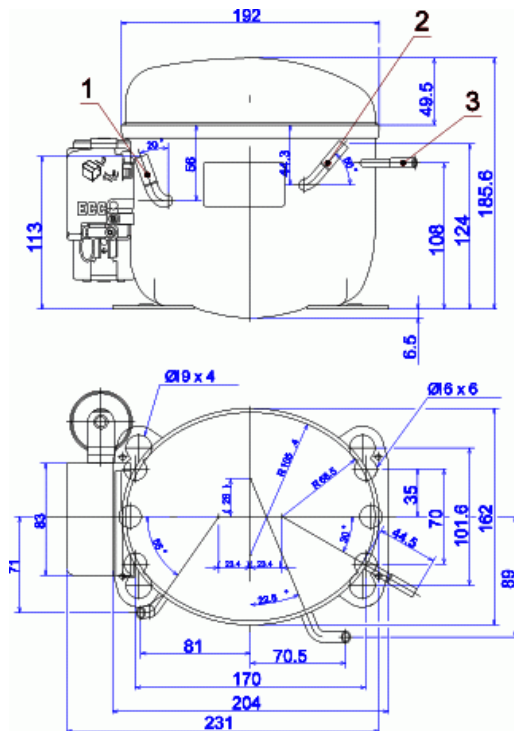
DIMENSIONS AND ELECTRICAL DIAGRAM

DESIGNATION	INTERNAL DIAM. (MM)
1 Suction/Service	6,5
2 Service/Suction	6,5
3 Discharge	4,9

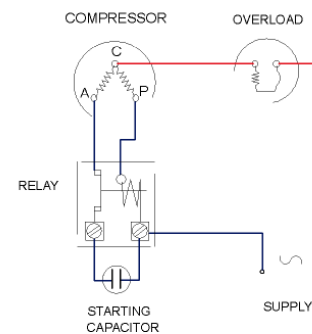
CSIR

TEST CONDITIONS

Voltage/frequency	220V 50Hz
Ambient t. and return	35 °C
Liq.t. entering expan.	Subcooling 9 K

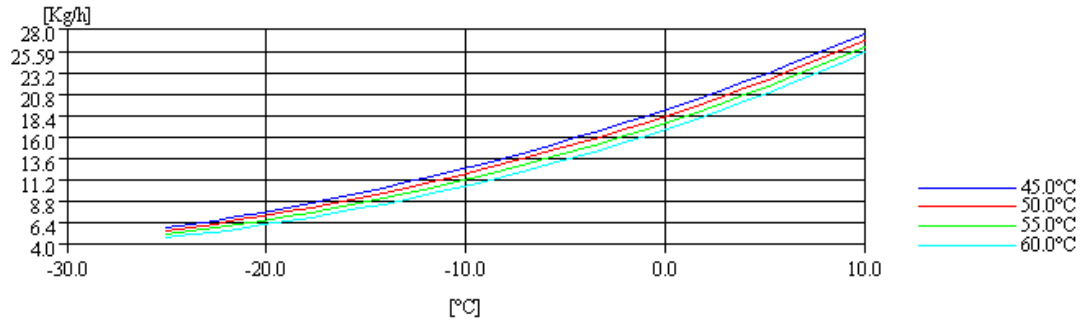
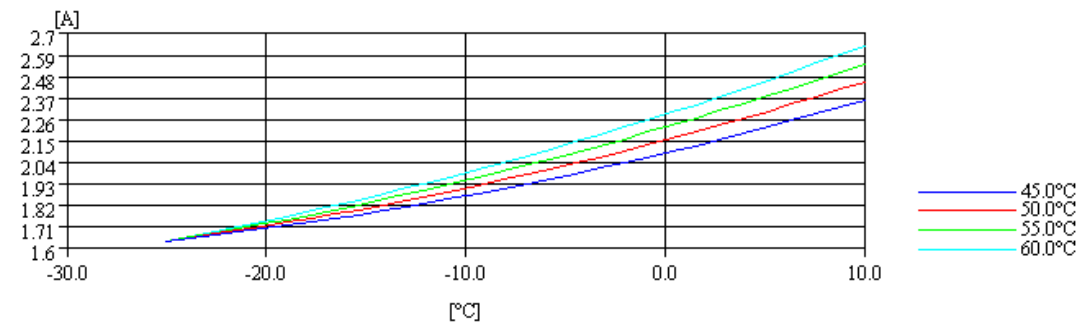
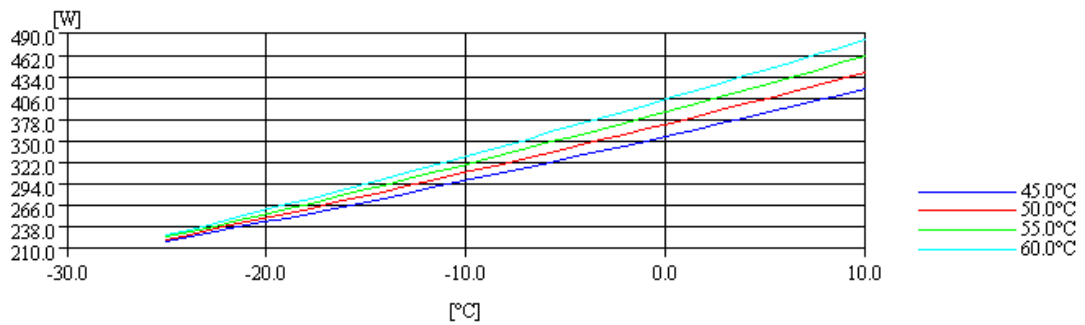
MASS FLOW

INTENSITY

CONSUMPTION

COOLING CAPACITY
