

COMPRESSOR

Displacement (cm ³)	8.1
Diameter (mm)	24.29
Stroke (mm)	17.48
Net Weight (Kg)	10.9
Oil type	ISO VG 46 ESTER
Oil charge (cm ³)	300

MOTOR

Approximate Power (CV)	1/4
Voltage/Frequency (V/Hz)	220V 50Hz
Voltage range (V)	187-264
Code	65.503
Type	CSIR
Phase number	1 PH
Locked rotor current (A)	12.2
Main W. resist. at 25°C (Ω)	8.42
Start W. resist. at 25°C (Ω)	29.75

APPLICATION

Application	Low back pressure
Refrigerant	R404A
Evaporating (°C)	-40 to -10
Expansion	Capillar/Valve
Comp. cooling	Fan cooled
Max. ambient temp. (°C)	43

NOMINAL PERFORMANCE	CYCLE A	CYCLE B
Cooling capacity (kcal/h)	217	320
Input power (W)	324	340
EER (kcal/Wh)	0.67	0.94
COP (W/W)	0.77	1.09
Current (A)	2.03	2.09

TEST CONDITIONS

Evaporating temp. (°C)	-25.0	-23.3
Condensing temp. (°C)	55.0	55.0
Liq.t. entering expan. (°C)	55.0	32.0
Ambient t. and return (°C)	32.0	32.0
Tens/Freq (V/Hz)	220V 50Hz	220V 50Hz

ELECTRICAL COMPONENTS

Relay	2014 145.	
Pick-Up (A)	7,10	
Drop-Out (A)	6,00	
Protector	MRT40AMK	T0137
Current (A)	9.5	9.5
Time check (seg)	7.5-14	7.5-14
Disc temp. (Open/Close) (°C)	105.0 / 61.0	110.0 / 61.0
Starting capacitor (μF/V)/F/V)	47- 56 / 330	

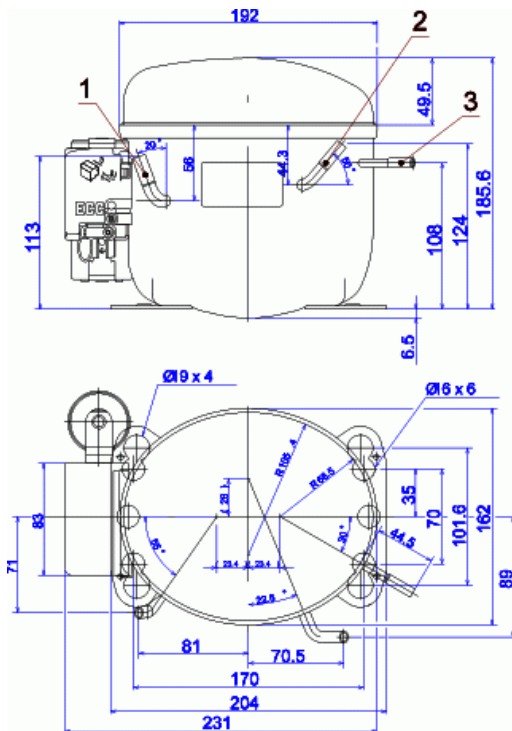
DIMENSIONS AND ELECTRICAL DIAGRAM

DESIGNATION	INTERNAL DIAM. (MM)
1 Suction/Service	6,5
2 Service/Suction	6,5
3 Discharge	4,9

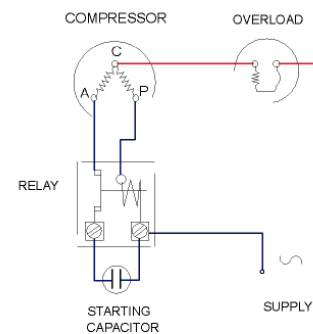
CSIR

TEST CONDITIONS

Voltage/frequency	220V 50Hz
Ambient t. and return	32 °C
Liq.t. entering expan.	Subcooling at 32 °C

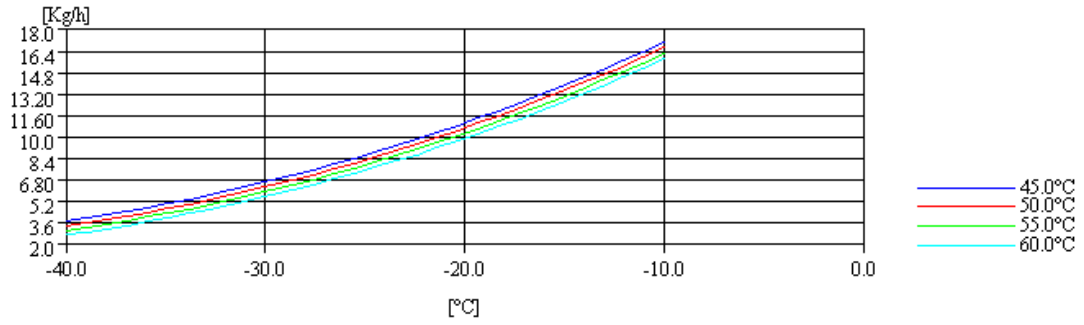
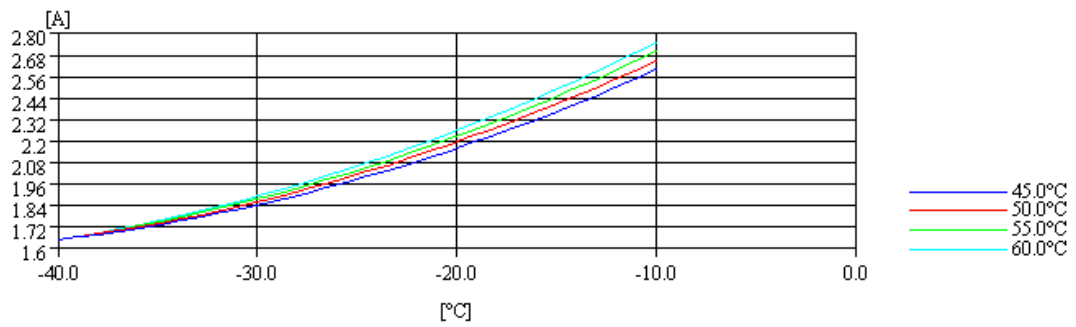
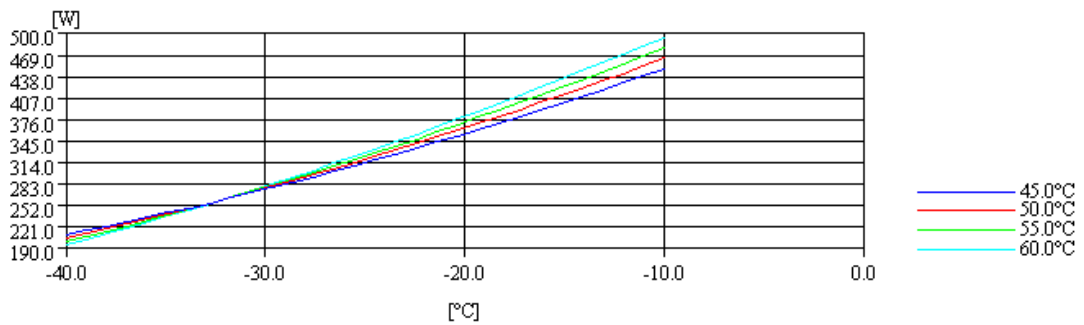
MASS FLOW

INTENSITY

CONSUMPTION

COOLING CAPACITY
