



## 1.规格 SPECIFICATION

## 1-1、压缩机要项 PRINCIPAL ITEMS OF COMPRESSOR

空调机的型式 AIR CONDITIONER TYPE	冷暖兼用型空调机 COOLING & HEATING
压缩机的型式 COMPRESSOR TYPE	全封闭型电动压缩机 HERMETIC MOTOR COMPRESSOR
压缩机方式 COMPRESSION TYPE	旋转式 ROTARY
通过的安全认证 Safety Approval	<b>TUV</b>
使用冷媒 REFRIGERANT	<b>R410A</b>
润滑油名·油量 OIL·OIL CHARGE	<b>ESTER OIL VG74 · 400</b> ml
涂装 PAINTING	黑色 BLACK COLOR PAINT
总质量（含润滑油量） NET MASS（OIL INCLUDED）	<b>12.6</b> kg
排除容积 DISPLACEMENT	<b>14.7</b> cm <sup>3</sup> /rev
吸气管内径 SUCTION TUBE(I.D)	<b>12.9</b> mm
排气管内径 DISCHARGE TUBE(I.D)	<b>8.1</b> mm

## 1-2 电机 MOTOR

电机的型式·起动方式 MOTOR TYPE·STARTING TYPE	单相诱导电机·运转电容型 SINGLE PHASE INDUCTION MOTOR · PSC
极数 POLE	极 2 POLE
额定电压频率 RATED VOLTAGE·FREQUENCY	单相 <b>1φ-50Hz-220/240V</b>
额定回转数 RATED REVOLUTION	<b>47.5/47.8±1%</b> S-1
绝缘等级 INSULATION GRADE	类 E GRADE
绕组阻抗 WINDING RESISTANCE(20℃)	主绕组 辅绕组 Main: <b>2.79±5% Ω</b> Aux.: <b>4.73±5% Ω</b>
起动电流 STARTING CURRENT	(at 1φ-50Hz-220/240V) <b>26.7+10%</b> A

1-3、电气部品规格.配线接线图 ELECTRICAL COMPONENT & WIRING DIAGRAM

品名 PARTS NAME	规格 SPECIFICATION
运转电容 RUNNING CAPACITOR	(用户自己准备 Out of Supply) 电容容量 Capacity : <b>35</b> $\mu$ F 耐压 Withstanding Voltage: $\geq$ <b>370</b> VAC
过载保护器 OVER LOAD PROTECTOR	内置 INTERNAL (IOL)

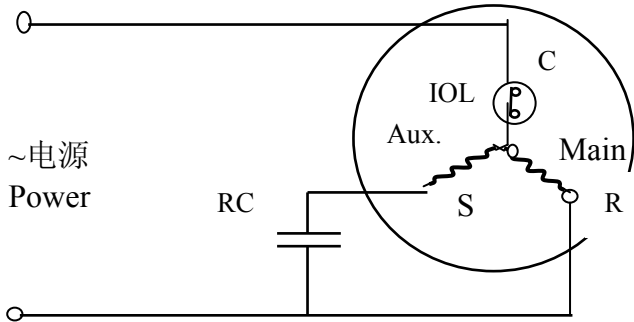

S: START (辅绕组 AUX WINDING)  
 R: RUN (主绕组 MAIN WINDING)  
 C: COMMON (共通)  
 RC: 运转电容 RUNNING CAPACITOR  
 IOL: 内置保护器 Internal Overload Protector

2. 压缩机及标准附属品一览 COMPRESSOR & STANDARD ACCESSORY

品名 PARTS NAME	型号 TYPE (MODEL)	个数 PIECES	图纸代号 DRAWING CODE	备注 Note
外形图 DRAW EXTER	PA145G1C-4FT1	1	<b>1K319024Gr</b>	.....
橡胶垫 RUBBER CUSHION	$\phi$ 176底脚用 FOR BASE OF $\phi$ 176-TYPE	3	<b>1K15910311</b>	.....
端子盖 TERMINAL COVER	定速机共用 FOR FIXED FREQUENCY MODELS	1	<b>1K14722211</b>	.....
端子垫片 TERMINAL PACKING	定速机共用 FOR FIXED FREQUENCY MODELS	1	<b>1K14720132</b>	.....
端子螺母 TERMINAL NUT	定速机共用 FOR FIXED FREQUENCY MODELS	1	<b>1K14300711</b>	.....
接地螺钉 EARTHING HEX BOLT	* 铜质镀镍螺钉 NI-PLATED COPPER BOLT	1	<b>1K14300210</b>	Note: GMCC Not deliver; 客户自己准备
接地螺钉垫片 WASHER FOR EARTHING BOLT	* 铜质镀镍垫片 NI-PLATED COPPER WASHER	1	<b>1K14300310</b>	Note: GMCC Not deliver; 客户自己准备

请用广东美芝指定之压缩机零部件和附属品。

USE COMPRESSOR PARTS AND ACCESSORIES SPECIFIED BY GMCC

**\* ! 请注意 ! Attention:**

如使用压缩机底脚上的接地孔，务必将原压缩机上的防锈保护钢质螺钉与垫片卸下废弃，换上附件中的铜质螺钉与垫片或相当品。

If the Earthing Hole on the Base of Compressor will have been connected with Earthing Wire, Please Remove and throw away the Antirust Steel Bolt and Washer which has been installed on Compressor, and Use the Copper Bolt and Washer listed above or Equivalent.

3. 运转标准 STANDARD OF PERFORMANCE

3-1、性能 RATED PERFORMANCE

			(参考) GB 条件时 AT GB STANDARD
冷冻能力/CAPACITY	W	☆	<b>3585/3620</b> ± 5%
输入功率/MOTOR INPUT	W	☆	<b>1240/1330</b> ± 5%
电流/CURRENT	A	☆	<b>5.85/6.10</b> ± 5%
COP	W/W %	☆	<b>289/272</b> ± 5%

☆测定条件 RATING CONDITIONS

- 额定电压 RATED VOLTAGE :1φ-50Hz-220/240V
- 冷凝温度 COND.TEMP. :54.4℃
- 蒸发温度 EVAP.TEMP :7.2℃
- 吸气温度 RETURN GAS TEMP :35℃
- 过冷却液温 LIQUID TEMP. :46.1℃
- 环境温度 AMBIENT TEMP. :35℃
- 强制空冷 FORCED AIR

※根据广东美芝量热标准

ACCORDING TO GMCC'S CALORIEMETER STANDARD

运转停止电压 B.D.V	V	<b>198</b> 以下 MAX	Pd/Ps=4.15/1.15 MPa
起动电压 STARTING VOLTAGE	V	<b>187</b> 以下 MAX	Pd=Ps=1.57 ± 0.1 MPa Pd-Ps ≤ 0.05 MPa

3-2、一般特性 CHARACTERISTICS

气密试验压力 (AP) LEAK TIGHT PRESSURE	高压侧 HIGHER PRESSURE SIDE	<b>4.3</b> MPa
	低压侧 LOWER PRESSURE SIDE	<b>2.1</b> MPa
耐压试验压力 (TP) HYDROSTATIC STRENGTH PREESSURE	高压侧 HIGHER PRESSURE SIDE	<b>6.3</b> MPa
	低压侧 LOWER PRESSURE SIDE	<b>3.2</b> MPa
绝缘阻抗 (封入氮气时) INSULATION RESISTANCE ( FILLED WITH NITROGEN GAS)		以上 20 MΩ MIN
绝缘耐压 / 泄漏电流 WITHSTAND VOLTAGE/LEAKAGE CURRENT		<b>AC1500V-1min / 10 MA MAX</b>
残余水分量 RESIDUAL MOITSTURE	• 含尘量 • RESIDUAL IMPURITIES	<b>160mg</b> 以下 • <b>45mg</b> 以下 MAX • MAX
接地阻抗 EARTHING RESISTANCE		以下 <b>0.1</b> Ω MAX

4、使用条件范围 OPERATING CONDITIONS

项目 ITENS	负荷 LOAD	标准 STANDARD	最高 MAX.
----------	---------	----------------	------------

排气压力 DISCHARGE PRESSURE	MPa(G)	3.28	以下 MAX	4.15	以下 MAX
吸气压力 SUCTION PRESSURE	MPa(G)	0.89		0.23~1.15	
压缩比 COMPRESSION RATIO		8	以下 MAX	8	以下 MAX
绕组温度 MOTOR COIL TEMP.	℃	100	以下 MAX	125	以下 MAX
排气管温度 DISCHARGE TUBE TEMP.	℃	100	以下 MAX	115	以下 MAX

※ 空调系统设计制造注意事项 SYSTEM DESIGN AND PROCESS LIMITATIONS

许容冷媒封入量 LIMIT OF REFRIGERANT AMOUNT	kg	<b>1.00 kg</b> 以下 MAX			
连续液返回量 CONTINUOUS FLOOD BACK		连续液在储液罐前的返回量不超过总冷媒循环量的 10% CONTINUOUS FLUID BACK BEFORE THE ACCUMULATOR NOT BE MORE THAN 10% OF TOTAL CIRCULATION QUANTITY OF REFRIGERANT.			
异常音、异常电流 ABNORMAL NOISE & CURRENT		起动时和冷冻循环切换时没有异常音及异常电流发生 KNOCKING NOISE OR OVERCURRENT SHOULD NOT OCCUR AT START-UP OR REVERSING CYCLE.			
温差ΔT: TEMP.DIFFERENT℃ (ΔT=壳底部温度-冷凝温度) (ΔT=CASE BOTTOM TEMP -CONDENSING TEMP		连续运转时(包含除霜、除湿)温差在 5℃以上。控制运转时在 0℃以上。 5 OR MORE: CONTINUOUS OPERATION 5 OR MORE: DEFROSTING OPERATION 5 OR MORE: DRY OPERATION 0 OR MORE: CONTROLLED INTERMITTENT OPERATION			
断续运转间隔、次数 INTERMITTENT OPERATION TIMES		每一循环 5 分钟以上(ON2 分钟以上、OFF2 分钟以上)。20 万次冷冻循环以下。 200000 CYCLES OR LESS, 5 MINUTES OR MORE (ON: 2MINUTES OR MORE, OFF: 2MINUTES MORE)			
运转电压波动允许范围 SUPPLY VOLTAGE RANGE		<b>220V-10%~240V+10%(198~264V)</b> 以内 THE SUPPLY VOLTAGE SHOULD BE <b>220V-10%~240V+10%(198~264V)</b>			
运转频率允许范围 POWER FREQUENCY		额定频率的±2%以内 THE POWER FREQUENCY SHOULD BE THE RATED VALUE ±2%			
起动时的压力差 PRESSURE DIFFERENCE AT START-UP		起动时高压侧和低压侧压力平衡 THE PRESSURE SHOULD BE BALANCED THE HIGH-PRESSURE AND LOW-PRESSURE SIDES AT START-UP			
许容运转倾斜度 TILT IN OPERATION		压缩机在倾斜角 5° 以内可以正常运转 COMPRESSOR SHOULD BE RUN AT A GRADIENT OF UP TO 5°			

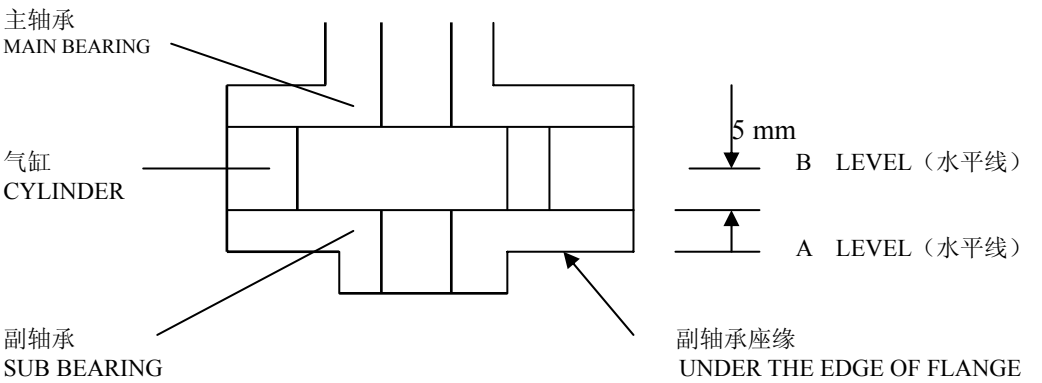
<p>许容油面高度 LUBRICATION OIL LEVEL</p>	<p>压缩机润滑油面高度标准如下图，但是见到润滑油起泡时，起泡部份不计入在内。 THE LUBRICATION OIL LEVEL IN A COMPRESSOR SHOULD BE AS LISTED BELOW IF THE LUBRICATION OIL IS FOAMING FOAM SHOULD BE EXCLUDED FROM THE OIL LEVEL</p> <table border="1" data-bbox="406 347 1452 940"> <tr> <td colspan="2">运转条件 OPERATING CONDITION</td> <td>润滑油面 OIL LEVEL</td> </tr> <tr> <td colspan="2">连续运转时 IN CONTINUOUS OPERATION</td> <td>B水平线以上 B LEVEL OR HIGHER</td> </tr> <tr> <td rowspan="2">起动时 WHEN STARTING</td> <td>动转起动时 CONTROLLED START</td> <td>B水平线以上 B LEVEL OR HIGHER</td> </tr> <tr> <td>冷媒沉积时起动 AFTER SOAKING</td> <td>B水平线以上。起动3分钟之后油面在A水平线以上。 B LEVEL OR HIGHER, A LEVEL OR HIGHER WITHIN 3MINUTES AFTER START-UP</td> </tr> <tr> <td rowspan="2">除霜时 IN DEF-ROSTING</td> <td>热气除霜 DEFROSTING-HOT GAS</td> <td>B水平线以上 B LEVEL OR HIGHER</td> </tr> <tr> <td>逆向除霜 REVERSE CYCLE</td> <td>B水平线以上 B LEVEL OR HIGHER</td> </tr> </table> 	运转条件 OPERATING CONDITION		润滑油面 OIL LEVEL	连续运转时 IN CONTINUOUS OPERATION		B水平线以上 B LEVEL OR HIGHER	起动时 WHEN STARTING	动转起动时 CONTROLLED START	B水平线以上 B LEVEL OR HIGHER	冷媒沉积时起动 AFTER SOAKING	B水平线以上。起动3分钟之后油面在A水平线以上。 B LEVEL OR HIGHER, A LEVEL OR HIGHER WITHIN 3MINUTES AFTER START-UP	除霜时 IN DEF-ROSTING	热气除霜 DEFROSTING-HOT GAS	B水平线以上 B LEVEL OR HIGHER	逆向除霜 REVERSE CYCLE	B水平线以上 B LEVEL OR HIGHER
运转条件 OPERATING CONDITION		润滑油面 OIL LEVEL															
连续运转时 IN CONTINUOUS OPERATION		B水平线以上 B LEVEL OR HIGHER															
起动时 WHEN STARTING	动转起动时 CONTROLLED START	B水平线以上 B LEVEL OR HIGHER															
	冷媒沉积时起动 AFTER SOAKING	B水平线以上。起动3分钟之后油面在A水平线以上。 B LEVEL OR HIGHER, A LEVEL OR HIGHER WITHIN 3MINUTES AFTER START-UP															
除霜时 IN DEF-ROSTING	热气除霜 DEFROSTING-HOT GAS	B水平线以上 B LEVEL OR HIGHER															
	逆向除霜 REVERSE CYCLE	B水平线以上 B LEVEL OR HIGHER															
<p>许容配管应力 TUBE STRESS</p>	<p>压缩机配管不要产生共振。对于配管施加之应力请控制在下表允许应力值之内，配管设计时考虑防止应力折损。 TUBE TO BE CONNECTED WITH A COMPRESSOR SHOULD BE FREE OF RESONANCE. THE TUBE STRESS SHOULD NOT EXCEED THE VALUES LISTED BELOW TUBE SHOULD NOT BREAK DURING OPERATION, AT START-UP, AND AT STOP</p> <table border="1" data-bbox="422 1579 1452 1948"> <thead> <tr> <th>振动模式 VIBRATION MODE</th> <th colspan="2">许容应力值（半振幅） ALLOWABLE TUBING STRESS (HALF AMPLITUDE)</th> </tr> </thead> <tbody> <tr> <td>运转时 OPERATING</td> <td>20N/mm<sup>2</sup></td> <td>以下 OR LESS</td> </tr> <tr> <td>起动时、停止时 START-UP STOP</td> <td>30N/mm<sup>2</sup></td> <td>以下 OR LESS</td> </tr> <tr> <td>运输时、装卸时 IN TRANSIT</td> <td>30N/mm<sup>2</sup></td> <td>以下 OR LESS</td> </tr> </tbody> </table>	振动模式 VIBRATION MODE	许容应力值（半振幅） ALLOWABLE TUBING STRESS (HALF AMPLITUDE)		运转时 OPERATING	20N/mm <sup>2</sup>	以下 OR LESS	起动时、停止时 START-UP STOP	30N/mm <sup>2</sup>	以下 OR LESS	运输时、装卸时 IN TRANSIT	30N/mm <sup>2</sup>	以下 OR LESS				
振动模式 VIBRATION MODE	许容应力值（半振幅） ALLOWABLE TUBING STRESS (HALF AMPLITUDE)																
运转时 OPERATING	20N/mm <sup>2</sup>	以下 OR LESS															
起动时、停止时 START-UP STOP	30N/mm <sup>2</sup>	以下 OR LESS															
运输时、装卸时 IN TRANSIT	30N/mm <sup>2</sup>	以下 OR LESS															
<p>压缩机禁止横放、倒置 DO NOT PUT A COMPRESSOR ON ITS SIDE OR TURN OVER.</p>																	

<p>压缩机承受的冲击负荷在 590m/s<sup>2</sup> 以下，此外，压缩机的附属品应免受冲击。（如端子盖等） AN IMPACT TO COMPRESSOR SHOULD BE LIMITED TO 590m/s<sup>2</sup> OR LESS ,NOT GIVE A SHOCK TO ACCESSORIES.</p>
<p>密封橡胶垫拔除后，请防止潮湿空气进入压缩机内部，请不要长时间放置。 DO NOT LEAVE THE PLUGS OF THE COMPRESSOR IN THE ATMOSPHERE FOR MANY HOURS AFTER OPEN FOR PREVENTING WATER FROM GETTING INSIDE。</p>
<p>空气运转时油质会加速劣化，绝对禁止。 AVOID OPERATION WITH AIR FOR PREVENTING THE LUBRICATION OIL’S DETERIORATION FROM ACCELERATING。</p>
<p>封入冷媒时请从冷凝器出口封入。 REFRIGERANT MUST ALWAYS BE FILLED FROM THE HIGHER SIDE OF THE REFRIGERATION CYCLE</p>
<p>绝对禁止压缩机逆向运转，逆运转过的压缩机不能再使用。 DO NOT REVERS COMPRESSOR OPERATION. DO NOT REUSE THE COMPRESSOR THAT ROTATED IN REVERS。</p>
<p>压缩机请不要放置在露天，请在-10~+65℃室内保管。 DO NOT ALLOW COMPRESSOR TO BE WEATHERED; STORE COMPRESSORS INDOOR AT -10~+65℃</p>
<p>连接压缩机引出线的长度要充分考虑压缩机振动，应留有余量。 LEAD WIRE CONNECTED TO A COMPRESSOR SHOULD HAVE A SUFFICIENT ALLOWANCE AGAINST VIBRATIONS OF A COMPRESSOR。</p>
<p>压缩机壳体表面温度可能会达 150℃ 高温，不容许配线或类似物接触压缩机表面。 SINCE THE COMPRESSOR TEMPERTURE MAY RISE AS HIGH AS 150℃， DO NOT ALLOW ELECTRIC CABLES OR THE LIKE TO DIRECTLY TOUCH COMPRESSORS。</p>
<p>压缩机的终端盖内禁止水滴，灰尘进入，必须做适当的防湿、防尘处理。 TAKE PRORER MOISTURE-PROOF OR DUST-PROOF MEASURES FOR THE COMPRESSOR TERMINAL BOX IF WATER DROPLETS, DUST, OR THE LIKE MAY OTHERWISE ENTER。</p>
<p>请注意压缩机外壳应避免与吸湿性的材料接触，以防止腐蚀。另外，不要暴露在腐蚀气体或有机物之中。 TURN ATTENTION TO GATHERING RUST ON IT’ S SHELL WHEN ALLOWED COMPRESSOR TO COME IN TOUCH WITH HYGROSCOPIC MATERIALS。 NOT BE EXPOSED TO CORROSIVE GASES OR ORGANIC SUBSTANCES。</p>
<p>使用在分体机的场合，最长配管不超过 15m，配管的高低落差最大 5m。除本规定情况外，有关使用条件范围也应满足。 FOR SPLIT TYPE AIR-CONDITIONERS, THE MAXIMUM PIPING LENGTH SHOULD BE 15m, AN ELEVATION DIFFERENCE SHOULD BE WITHIN 5m, ALSO THE REQUIREMENTS HEREIN SHOULD BE MET。</p>
<p>许容冷媒量超出使用状况，须另行协商决定压缩机规格（储液器容量、油量等）以及空调系统的规格（储液器、曲轴箱加热器、油分离器、控制装置等）。 IF GAS CHARGE AMOUNT OF REFRIGERANT SPECIFIED IS EXCEEDED, BOTH PARTIES SHOULD DISCUSS THE MATTER TO DETERMINE COMPRESSOR SPECIFICATION（ACCUMULATOR VOLUME, LUBRICATING OIL AMOUNT） AND SYSTEM SPECIFICATIONS（CRANK CASE HEATER, OIL SEPERATOR, ADDITONAL ACCUMULATOR, ETC.）。</p>
<p>没得到 GMCC 的授权请不要随意更改压缩机规格。R410A 之外的冷媒禁止使用，否则有发生爆炸的可能。（特别是绝对禁止空气压缩） DO NOT MODIFY A COMPRESSOR WITHOUT GMCC’S AUTHORIZATION. DO NOT FILL THE REFRIGERATION CYCLES WITH GAS EXCEPT R410A, AS A COMPRESSOR MAY GO-UP IN A BLAST。（ESPECIALY COMPRESSING AIR IS NOT PERMITTED）</p>

<p>不准手拎排气管进行搬运、装卸。 DO NOT PROVIDE ANY FORCE ON DISCHARGE TUBE WHEN COMPRESSOR IS MOVED AND TRANSFERRED</p>
<p>请不要裸手触摸运行中或刚停机正处于高温的压缩机，当心烫伤。 DO NOT TOUCH THE COMPRESSOR WITH BARE HANDS DURING OPERATION OR IMMEDIATELY AFTER STOPPAGE. THE COMPRESSOR IS AT A HIGH TEMPERATURE. THERE IS THE DANGER OF BURNS.</p>
<p>维修保养设备时必须配戴防护眼镜。由于焊枪温度过高，拆卸配管时，当心会有冷媒、油的溅出而导致烫伤或进入眼中。 WEAR SAFETY GOGGLES WHEN SERVICING THE UNIT. WHEN REMOVING THE TUBES BY HEATING IT WITH A BURNER, THERE IS THE DANGER OF BURNS OR EYE INJURY IF THE REFRIGERANT AND/OR OIL REMAINING IN THE TUBES IS EMITTED.</p>

5、 其它 THE OTHERS

5-1、 充填 N<sub>2</sub> 气体 SEALING WITH NITROGEN GAS.

旋转式压缩机为防止生锈，填充有氮气。橡胶栓塞拔下时确认氮气吐气声。

THE ROTARY COMPRESSOR ARE SEALED WITH NITROGEN GAS FOR RUST PREVENTION WHEN REMOVING THE RUBBER CAP, IT SHALL BE MADE SURE AUDIBLY THAT THE NITROGEN GAS REMAINS.

5-2、 包装 CONTAINER

压缩机包装式样依据本公司之标准。

A STANDARD CONTAINER SPECIFIED IN GMCC IS USED.

5-3、 规格书有效期限

本规格书经贵公司承认之日后即生效。如更改须再发行承认生效，以前之规格书便自动失效。

THIS DOCUMENT WILL EFFECTIVE AFTER GMCC'S RECEIPT WITH YOUR AUTHORIZED SIGNATURE WHEN DESIGN MODIFICATION IS APPROVED BY THE CUSTOMER , THE CURRENT DOCUMENT IS UNAVAILABLE.



**R410A冷媒压缩机使用压力条件范围**  
OPERATING CONDITIONS OF R410A REFRIGERANT COMPRESSOR

单位:MPa(表压)  
 UNIT:MPa(G)

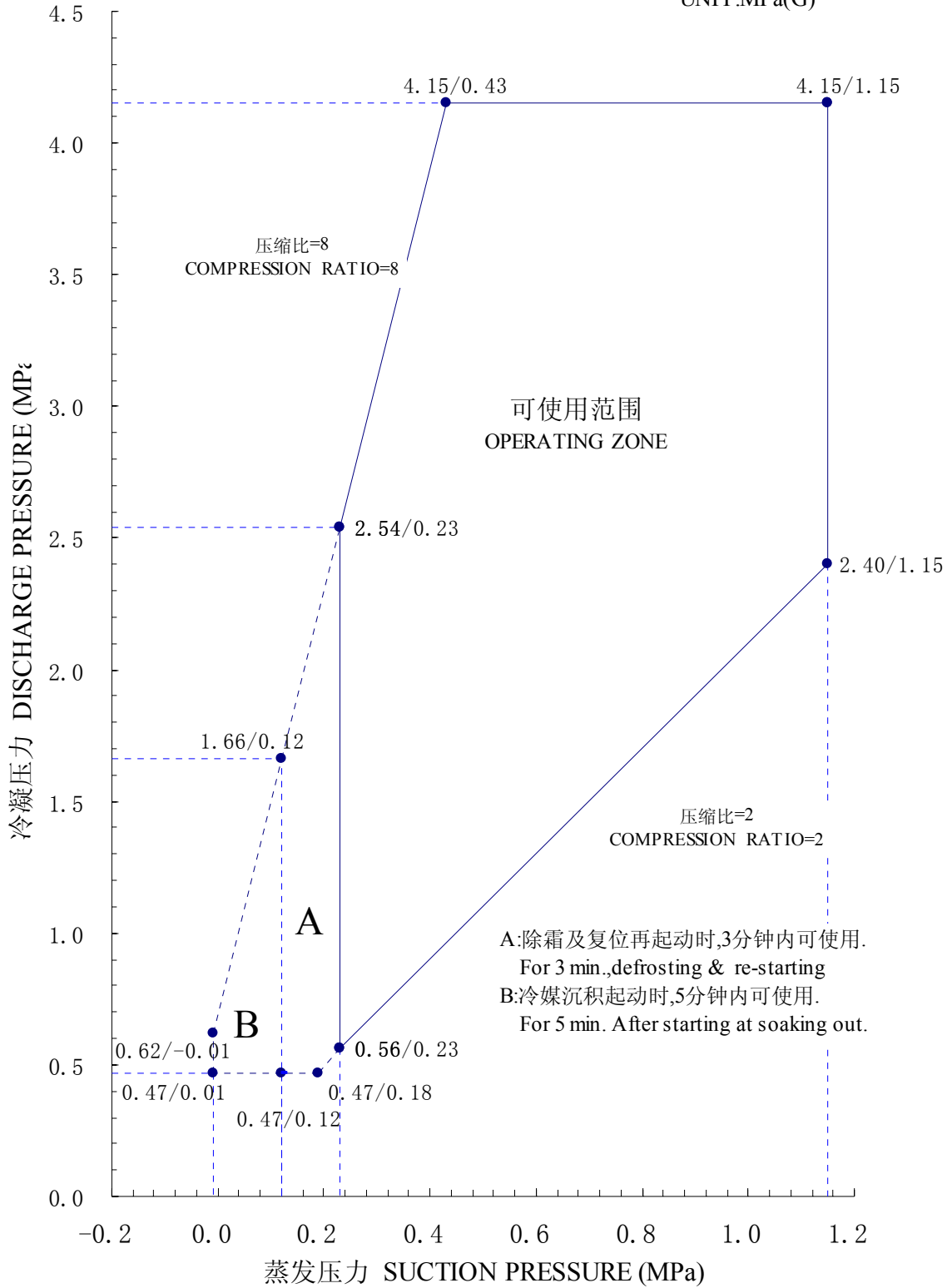

# ELE COMPONENTS

Drawing No. 1K14722114

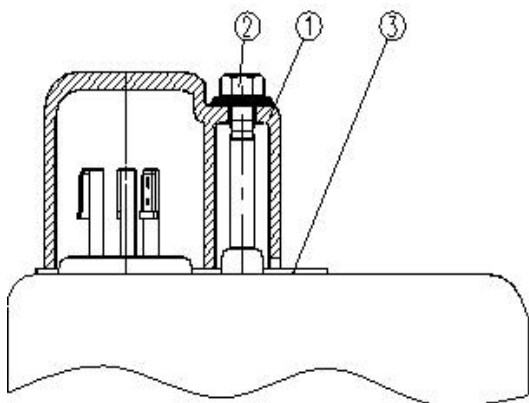
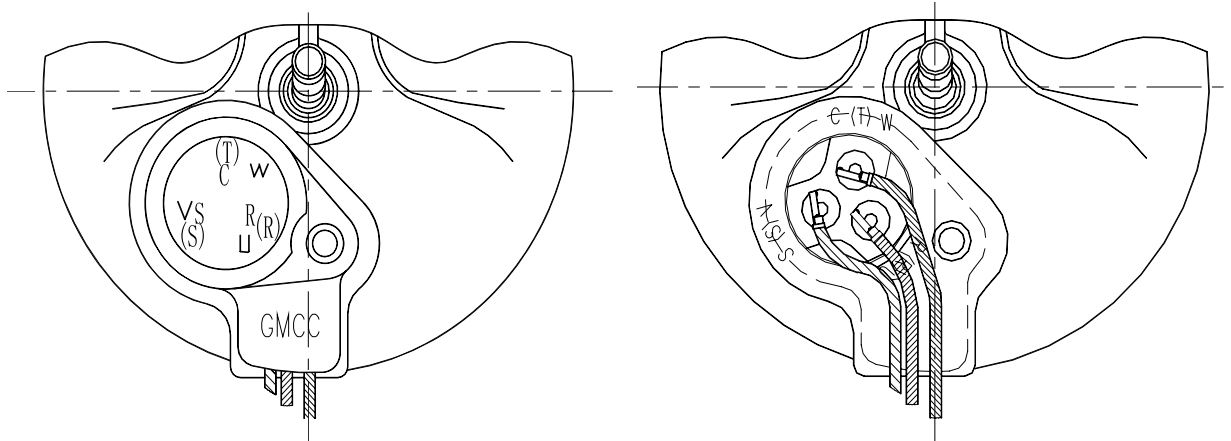

③	TERMINAL PACKING	1K14720132
②	TERMINAL NUT	1K14300711
①	TERMINAL COVER	1K14722211
PART NO	TITLE	DRAWN NO

## NOTES

Tightening torque of terminal nut:  $1.2 \pm 0.2 \text{ Nm}$

广东美芝制冷设备有限公司  
GUANGDONG MEIZHI COMPRESSOR LTD

# TERMINAL COVER

Drawing No. 1K14722211

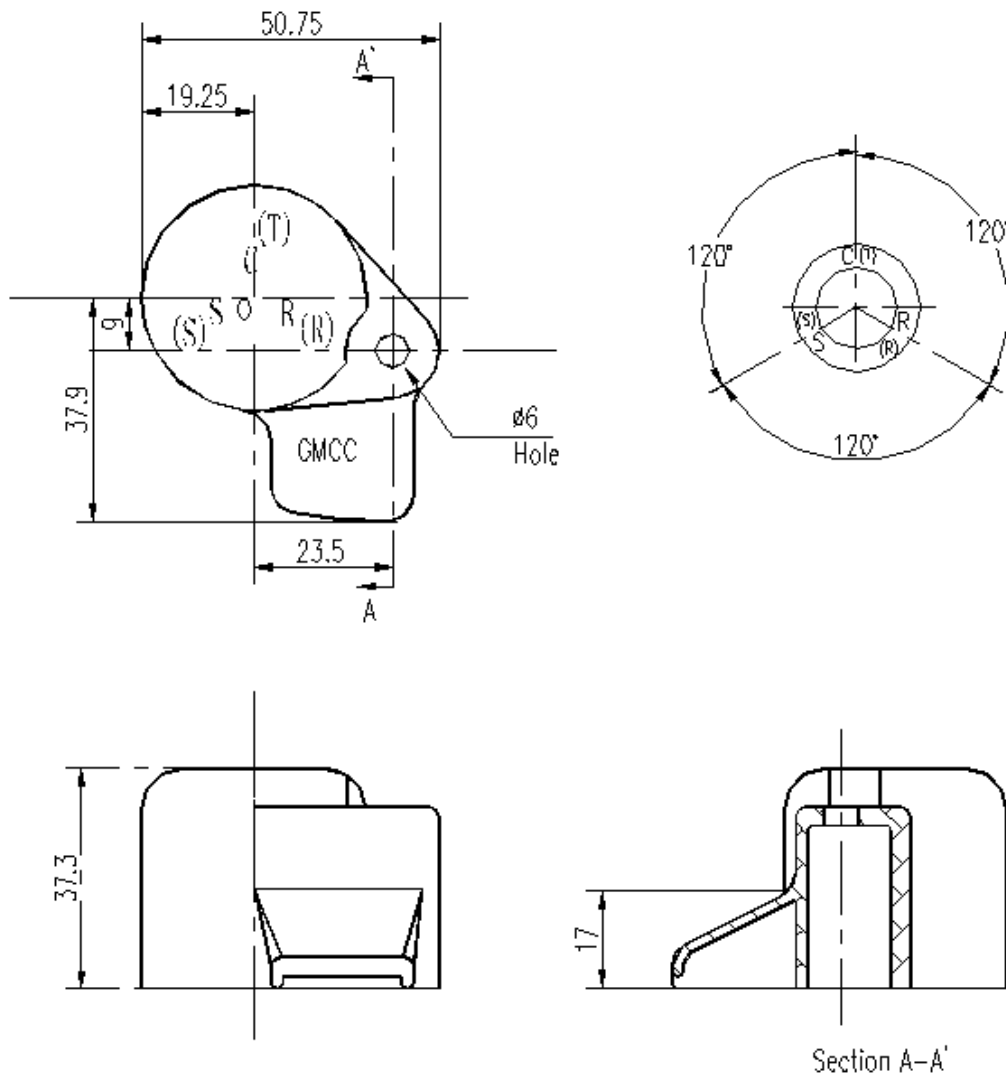

NOTES

MATERIAL: POLYBUTYLENE TEREPHTHALATE or Bulk molding compound

COLOR: BLACK

广东美芝制冷设备有限公司  
GUANGDONG MEIZHI COMPRESSOR LTD

# ELE COMPONENTS

Drawing No. 1K14722114

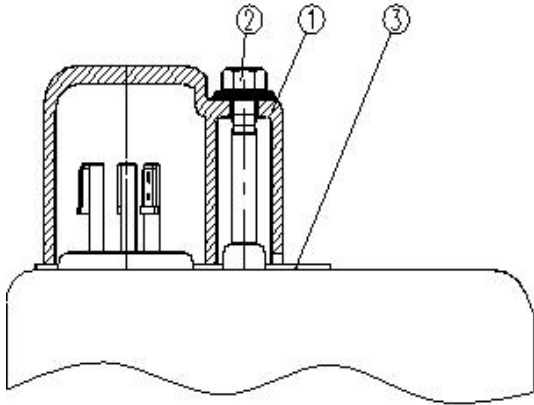
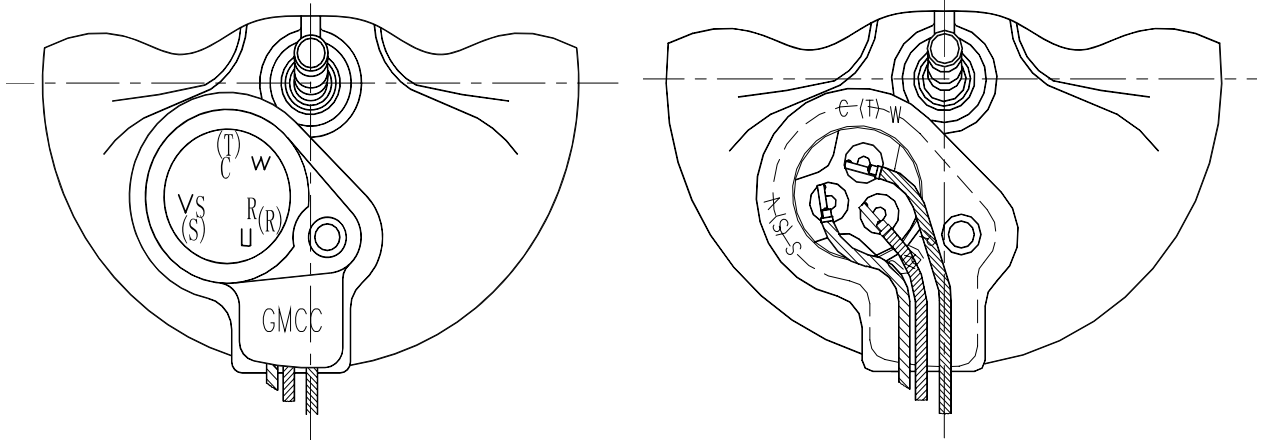

③	TERMINAL PACKING	1K14720132
②	TERMINAL NUT	1K14300711
①	TERMINAL COVER	1K14720013
PART NO	TITLE	DRAWN NO

NOTES

Tightening torque of terminal nut:  $1.2 \pm 0.2 \text{ Nm}$

广东美芝制冷设备有限公司  
 GUANGDONG MEIZHI COMPRESSOR LTD

# TERMINAL COVER

Drawing No. 1K14720013

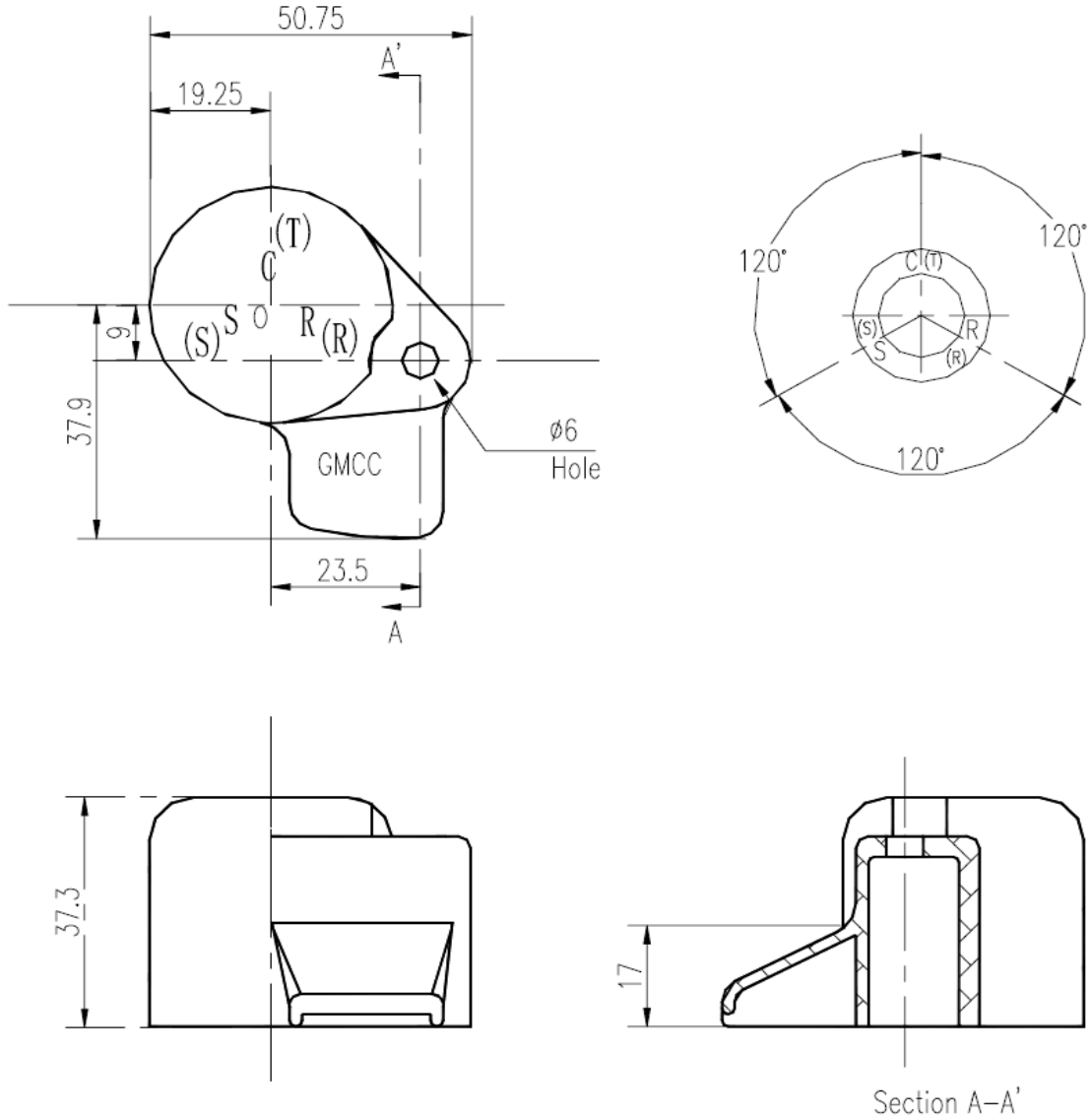

NOTES

MATERIAL:POLYBUTYLENE TEREPHTHALATE or Bulk molding compound or POLYCARBONATE

COLOR:BLACK

广东美芝制冷设备有限公司  
GUANGDONG MEIZHI COMPRESSOR LTD

# TERMINAL PACKING

Drawing No.1K14720132

THICKNESS 1mm

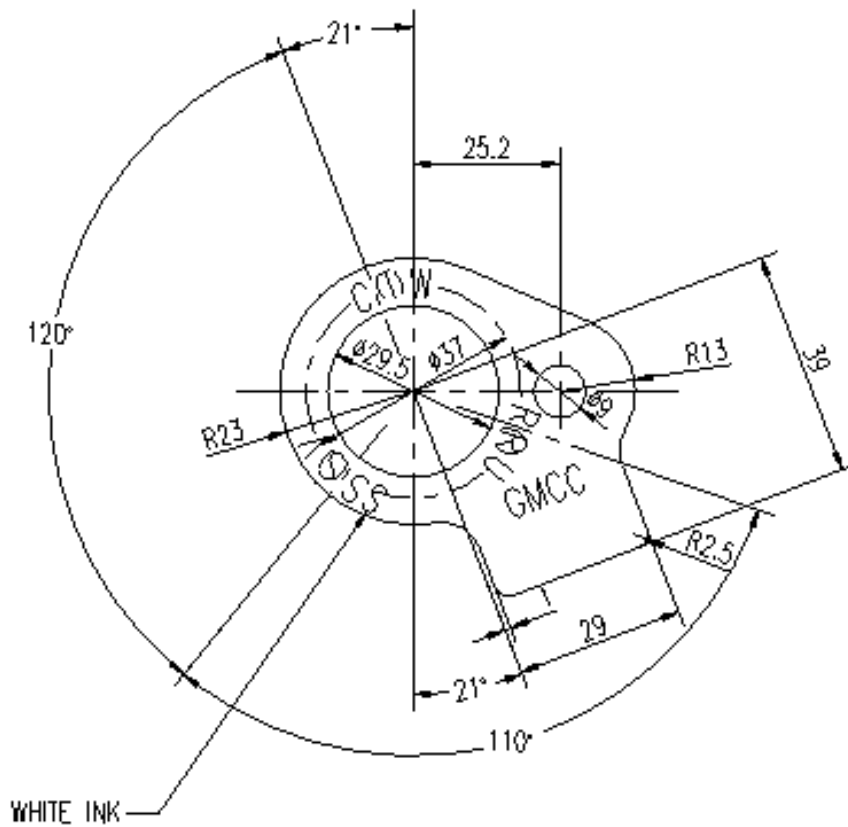

**NOTES**

**MATERIALS:SI**

**COLOR:BLACK**

广东美芝制冷设备有限公司  
GUANGDONG MEIZHI COMPRESSOR LTD

# TERMINAL NUT

Drawing No. 1K14300711

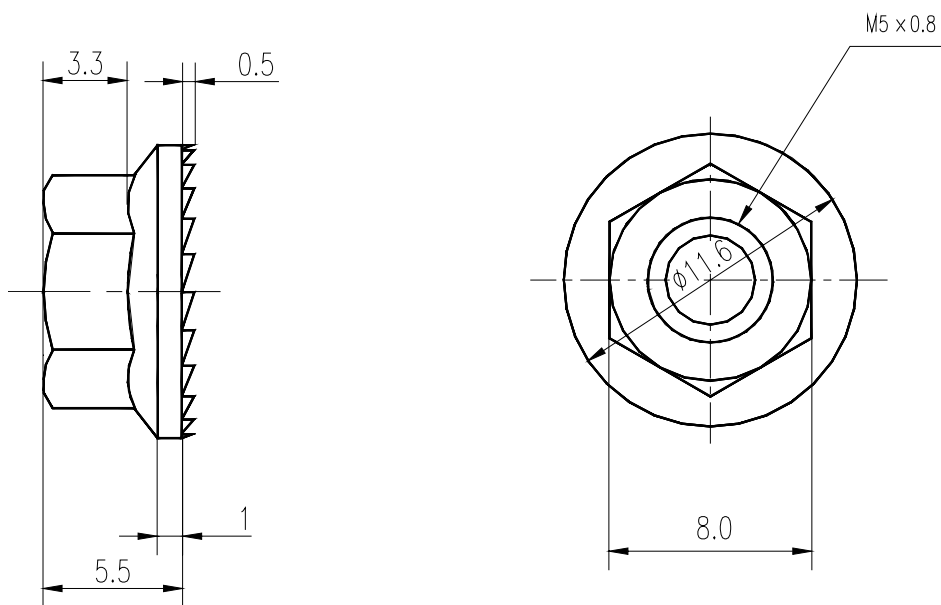

NOTES

MATERIAL: SWCH10

TREATMENT: WITHOUT HEXAVALENT CHROMIUM COMPOUNDS

广东美芝制冷设备有限公司  
GUANGDONG MEIZHI COMPRESSOR LTD

# RUBBER CUSHION

Drawing No.1K14910111

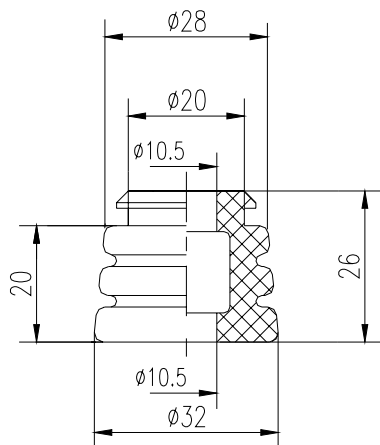

## NOTES

MATERIAL: EPDM

HARDNESS: HS=38

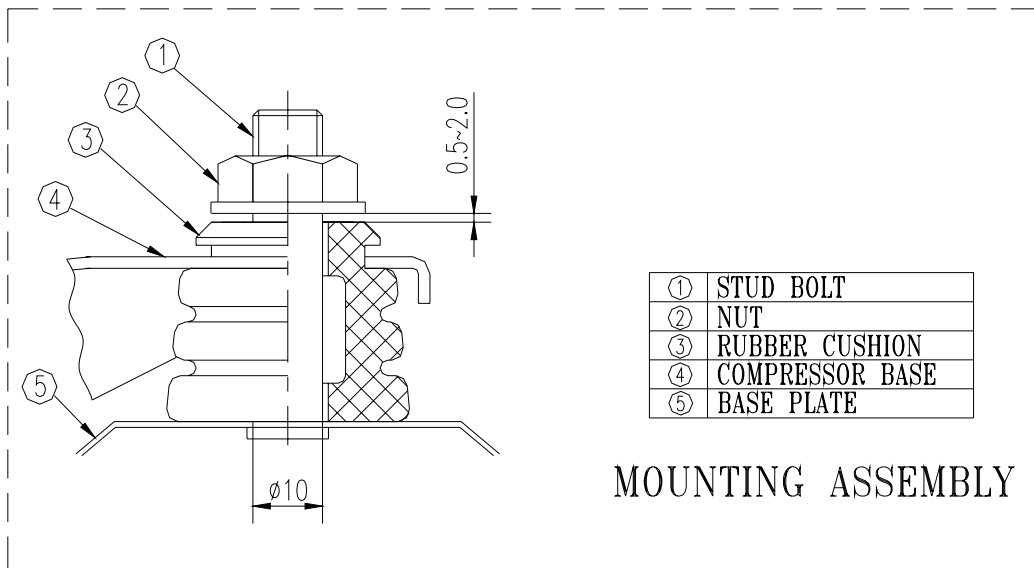



# RUBBER CUSHION

Drawing No. 1K15910311

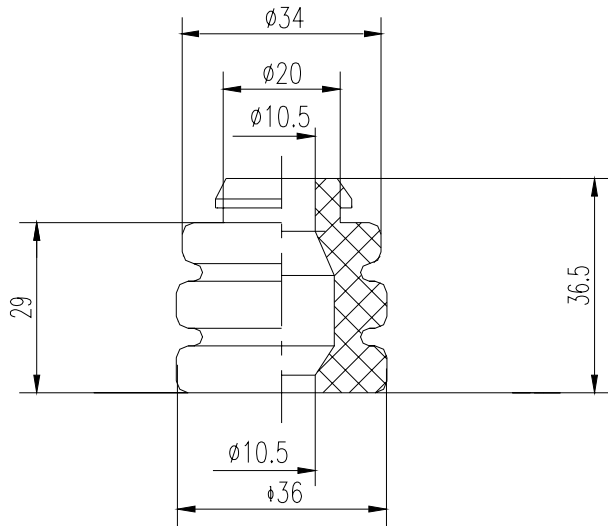

## NOTES

MATERIAL: EPDM

HARDNESS: HS=40°

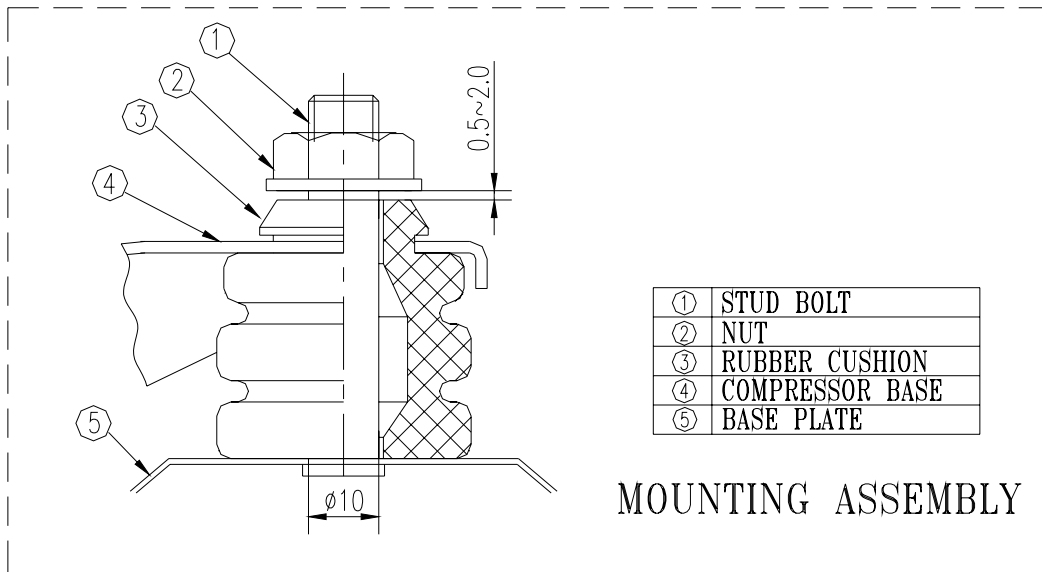

①	STUD BOLT
②	NUT
③	RUBBER CUSHION
④	COMPRESSOR BASE
⑤	BASE PLATE

## MOUNTING ASSEMBLY

# RUBBER CUSHION

Drawing No. 1K22910011

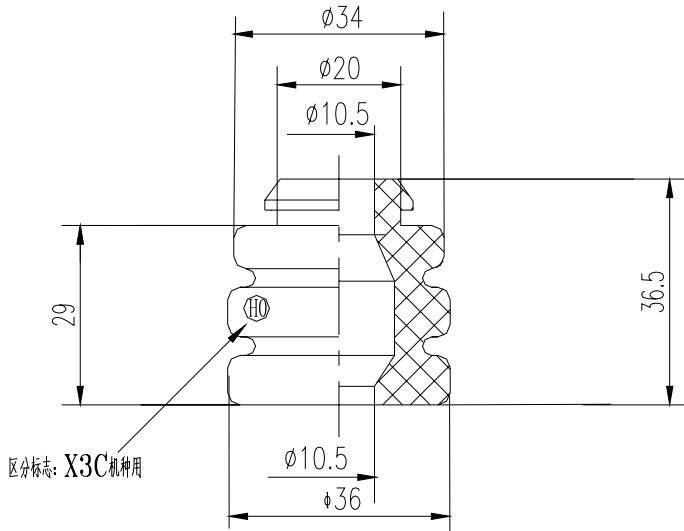

## NOTES

MATERIAL: EPDM

HARDNESS: HS=46°

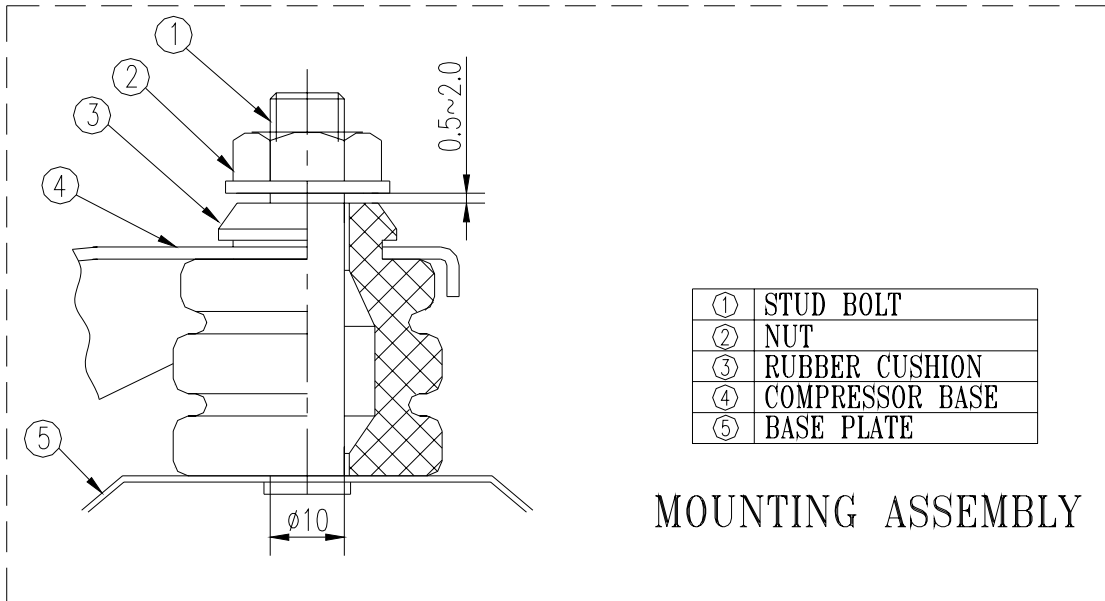

## MOUNTING ASSEMBLY

注意: X1C、X2C $\phi$ 176底脚机种用橡胶垫与X3C机种用橡胶垫(1K22910011)外形尺寸一样,仅硬度不同,请注意区分,

X3橡胶垫侧面有区分标志“HO”, X1C与X2C $\phi$ 176底脚用橡胶垫无“HO”标志。

美的海外专用

# RUBBER CUSHION

Drawing No. 1K22910011

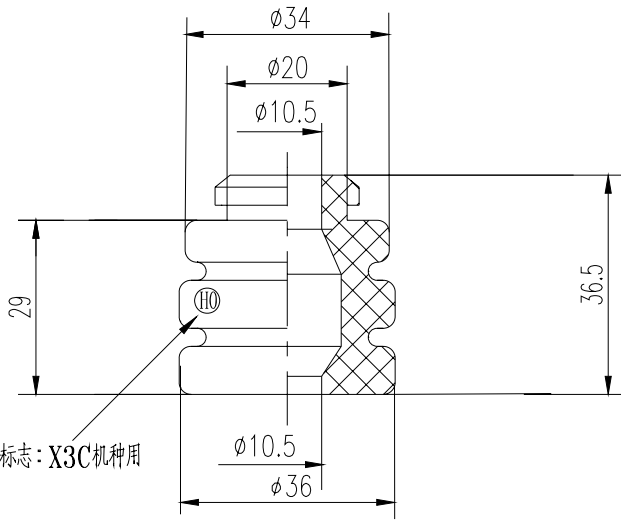

区分标志: X3C机种用

## NOTES

MATERIAL: EPDM

HARDNESS: HS=46

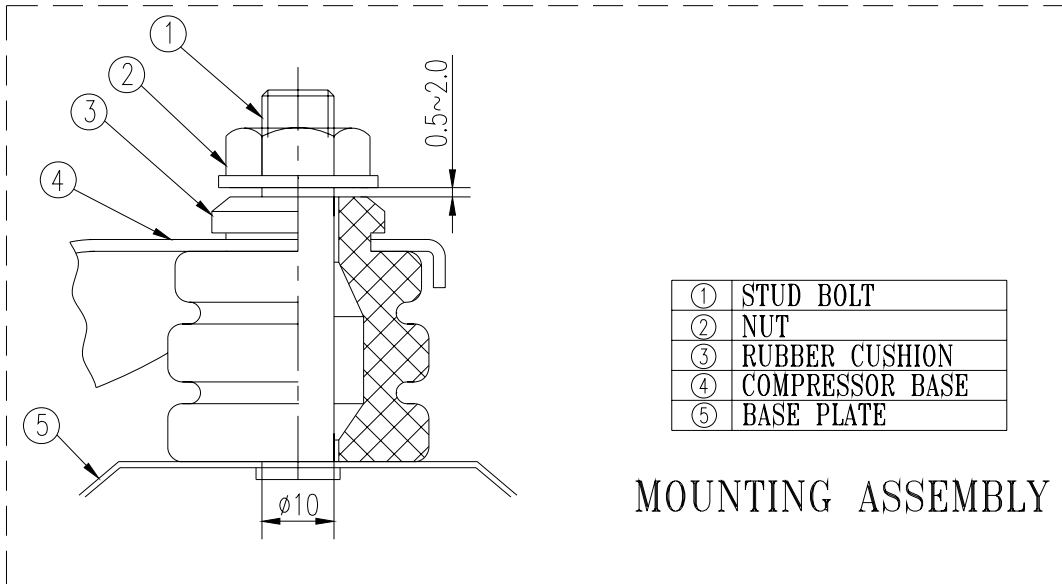

## MOUNTING ASSEMBLY

注意: X1C、X2C  $\phi 176$  底脚机种用橡胶垫与X3C机种用橡胶垫(1K22910011)外形尺寸一样, 仅硬度不同, 请注意区分, X3橡胶垫侧面有区分标志"HO", X1C与X2C  $\phi 176$  底脚用橡胶垫无"HO"标志。

# EARTHING HEX BOLT

Drawing No.1K14300210

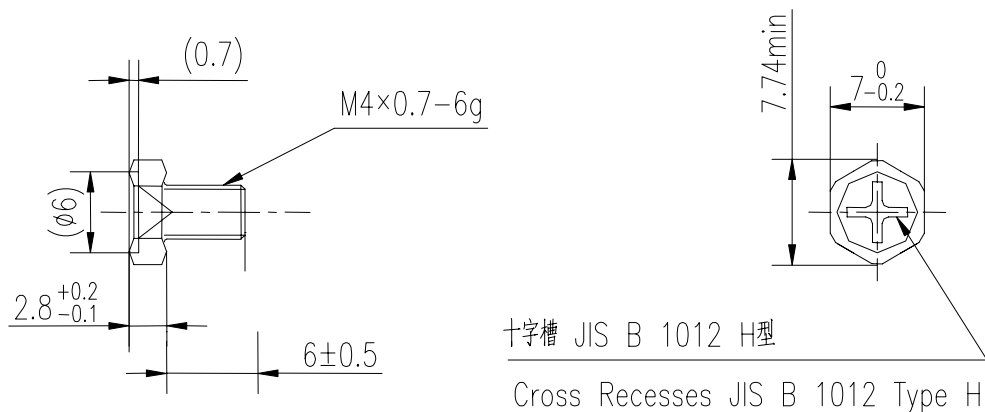

## NOTES

MATERIAL:C2700W-1/4H

TREATMENT:ELECTROPLATED COATINGS OF NICKEL(Ep-Cu/Ni 3 b)

广东美芝制冷设备有限公司  
GUANGDONG MEIZHI COMPRESSOR LTD

# WASHER FOR EARTHING BOLT

Drawing No.1K14300310

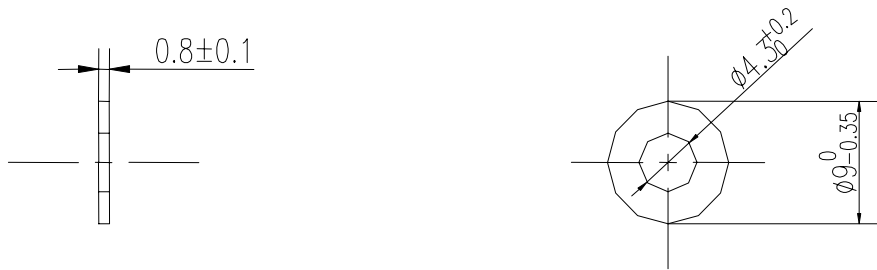

## NOTES

MATERIAL:C2700W1/4H

TREATMENT:ELECTROPLATED COATINGS OF NICKEL(EpCu/Ni 3 b)

广东美芝制冷设备有限公司  
GUANGDONG MEIZHI COMPRESSOR LTD

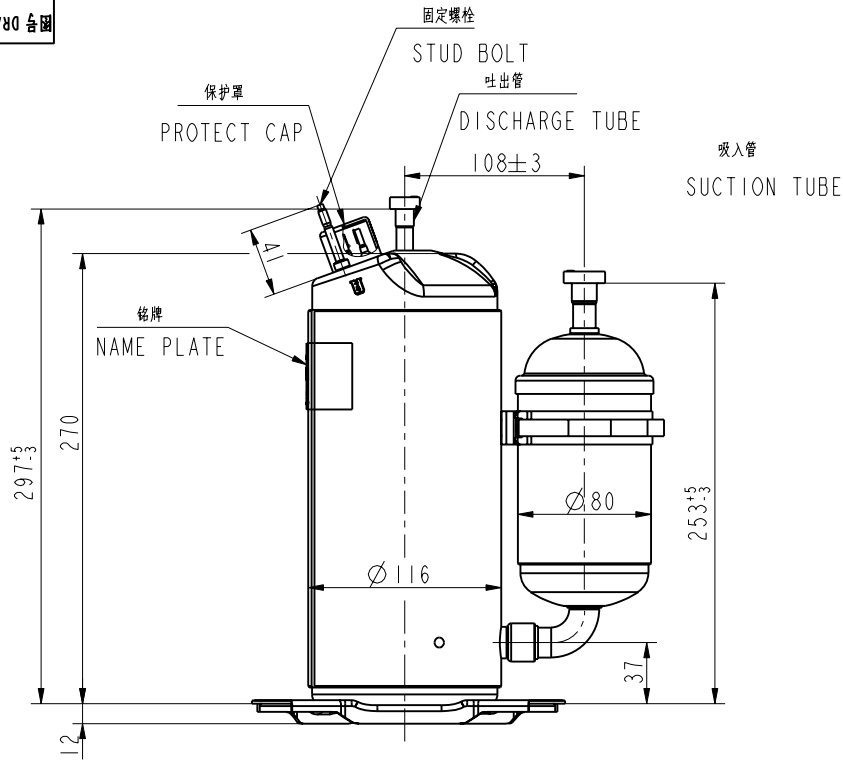

ACCUM侧其它外形详细  
 安装尺寸相同, 储液器外形以实物为准

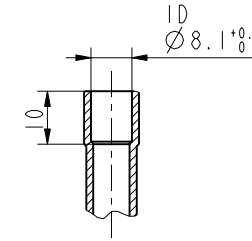
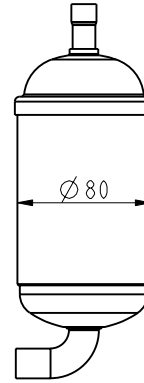

吐出管详细  
DISCHARGE TUBE

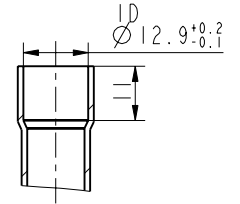

吸入管详细  
SUCTION TUBE

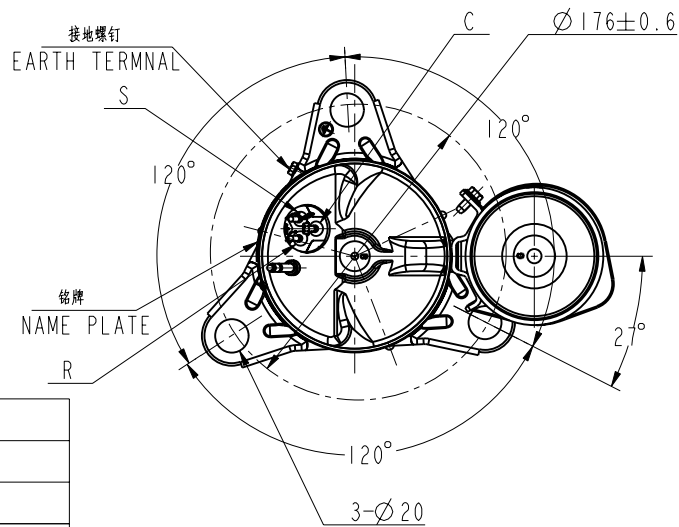

①	PA145GIC-4FTI	09.02.18
	PA140GIC-4FTI	08.11.11
	PA130GIC-4FTI	08.11.11
	机种名	年月日

①	I	71JD090278	张平	09.02.16
标记	处数	更改文件号	签字	日期
MARK	NUM.	REV. NO.	MODIFIED BY	DATE



设计 DESIGNED BY	郑立宇	工艺 TECHNOLOGY		简称 ABBR.	DRAW EXTER		图号 DRAWING NO.	IK319024Gr	
制图 DRAWN BY	高志远	标准化 STANDARD		材料 MATERIAL			名称 TITLE	外形图	
校对 CHECKED BY		审定 APPROVED BY		图样标记 STAGE OF DRAWING	重量 WEIGHT	比例 SCALE	DRAW EXTER		
审核 AGREED BY		日期 DATE		1	9		广东美芝制冷设备有限公司		
				共   页 TOTAL PAGE	第   页 PAGE NO.	GUANGDONG MEIZHI COMPRESSOR LTD			